

Research Article

Applications of Solar Energy Technologies in North Africa: Current Practices and Future Prospects

Abdulgader Alsharif ^{1,2*}, Abdussalam Ali Ahmed ³, Huda Elslam Mohamed ⁴, Mohamed Khaleel ⁵, Hamza Hebrisha ⁶,
Emad Almabsout ⁷, Mohamed Abou Sif ⁸, Yousef Al-Naas ²

¹ Department of Electrical & Electronics Engineering, Faculty of Technical Sciences – Sebha, Libya

² The Libyan Center for Solar Energy Researchers and Studies, Tripoli- Libya

³ Department of Mechanical Engineering, Faculty of Engineering, Bani Waleed University, Bani Waleed, Libya

⁴ College of Mechanical Engineering Technology, Benghazi, Libya

⁵ Department of Electrical-Electronics Engineering, Faculty of Engineering, Karabuk University, Karabuk, Turkey

⁶ Department of Electrical and Electronics Engineering, The College of Technical Sciences Misurata, Libya

⁷ Department of Electrical Engineering, Higher Institute of Engineering Technology, Benghazi, Libya

⁸ College of Civil aviation and meteorology, Espiaa, Libya

*Corresponding author: Abdelkaderalsharif@gmail.com

Received: June 27, 2023

Accepted: August 21, 2023

Published: August 26, 2023

This is an open access article under the BY-CC license

Abstract: Renewable energy sources (RESs) play a pivotal role in addressing both environmental and energy generation challenges. These sources have found multifaceted applications, ranging from charging Electric Vehicles (EVs) to powering household appliances, street lighting, and bolstering the utility grid. In the context of North African countries, RESs have emerged as a crucial solution to meet the region's surging energy demands while mitigating environmental concerns. The North African region, encompassing countries like Algeria, Egypt, Libya, Morocco, and Tunisia, is endowed with abundant solar energy potential due to its favorable climate and geographical positioning. Consequently, solar power initiatives, such as Concentrated Solar Power (CSP) and photovoltaic (PV) installations, are being extensively implemented to harness this profuse resource. The ultimate objective is to reduce reliance on Fossil Fuels (FF) and promote the adoption of clean and sustainable energy sources. This study endeavors to provide a comprehensive guide for researchers in the domain of solar power systems, offering valuable insights and perspectives in this critical area of research.

Keywords: Renewable Energy Sources; Electric Vehicle; Photovoltaic; North African Countries

1. Introduction

North African countries' governments are working towards green energy by exploiting the available natural sources to contribute to a sustainable world. The global environment and energy improvements [1]. This article shaded the lighting on the main basic components of solar systems and their applications in North African countries. The introduction of solar energy in North African countries has gained significant momentum in recent years [2]. The region is blessed with abundant sunlight, making it an ideal location for harnessing solar power [3]. North African countries, such as Morocco, Egypt, Algeria, Tunisia, and Libya, have been at the forefront of developing large-scale solar energy projects [4]. One of the prominent initiatives in the region is Morocco's Noor Solar Power Complex, located in the Sahara Desert [5]. It is one of the largest Concentrated Solar Powers (CSP) projects globally, helping generate clean electricity. Similarly, Egypt's Benban Solar Park is another notable venture, aiming to provide a significant portion of the country's electricity from renewable sources.

The advantages of solar energy in North African countries are numerous [6]. It reduces dependence on fossil fuels, decreases greenhouse gas emissions, and promotes energy security [7]. Moreover, solar

power contributes to job creation, technology transfer, and economic development within these nations [8]. However, challenges such as initial investment costs, infrastructure development, and grid integration need to be addressed. To overcome these barriers, governments, international organizations, and private investors are collaborating on various initiatives in order to address the aforementioned limitations. Additionally, regional cooperation and interconnection projects are being pursued to enhance energy trade between North African countries.

Over the last decade North Africa has managed to increase its renewable energy production by 40%, by adding 4.5 GW of wind, solar PV and solar thermal capacity to its renewable energy power fleet. Renewables generation capacity grew by 80% over the past ten years, and almost by 560%, when excluding hydropower. This progress has come despite significant recent social and political change in four countries in the region. As technologies have matured and costs have dropped, countries have increasingly been designing distinctive policies to promote energy transitions. Egypt's experiences are worth noting. The country went from chronic power shortages to having a 25% surplus of electricity supply by adding 25.5 GW of new generating capacity between 2015 and 2019 [9]. This included 1 GW of solar PV and nearly 840 MW of new wind capacity. Such transformation highlights an important lesson: it is entirely possible to address immediate energy challenges while also planning for a more sustainable future.

The introduction of solar energy in North African countries not only ensures a sustainable energy future but also provides opportunities for socio-economic growth and environmental preservation [10]. Moreover, wind energy is another significant renewable resource in North Africa. Countries like Morocco are investing in wind farms and coastal installations to harness the strong and consistent winds in certain regions [11]. This helps diversify their energy mix and reduce GHG emissions. While Libya is facing some of technical limitation that is why the wind energy is still not exploited [12]. Additionally, hydroelectric power generation is being explored in some North African countries. River basins in Algeria and Morocco offer potential for small to medium-scale hydroelectric projects [13]. These projects aim to utilize the flowing water to generate sustainable and reliable electricity [14].

Furthermore, biomass and bioenergy sources are being explored for sustainable energy production. Agricultural residues, organic waste, and dedicated energy crops can be utilized for biomass-based energy production, providing rural communities with clean and affordable energy alternatives [15]. North African countries are actively embracing renewable energy sources to transition towards a greener and more sustainable energy future [16]. These initiatives not only reduce environmental impact but also contribute to energy security, job creation, and socioeconomic development.

The main contribution of this article lies in its comprehensive presentation of the state-of-the-art on the classification of solar systems, highlighting their respective advantages and disadvantages, and addressing the pressing issue of energy crises in North African countries. By offering a detailed examination of the various types of solar energy systems and their potential benefits and drawbacks, the article serves as a valuable resource for researchers and policymakers in the field of renewable energy. Moreover, its insightful analysis of the energy challenges faced by North African nations provides valuable insights that can inform the development and implementation of sustainable energy strategies in the region. Overall, this article contributes to the advancement of knowledge and understanding in the domain of renewable energy, promoting informed decision-making and fostering sustainable energy solutions for the North African context. While the rest of the article is structured as follows: the general classification of renewable energy integration structures is listed in [Section 2](#). The common types of renewable energy sources along with their features and definition are placed in [Section 3](#). [Section 4](#) discuss the main structure of PV system tools with the key components and processes for solar PV recycling. The modern and developed smart software for PV system along with the sizing and simulation tools are formulated in [Section 5](#). Finally, this article is closing with the conclusion and list of recent references in the literature.

2. Renewable Energy Integration Structures

PV integration hybrid systems combine solar photovoltaic (PV) technology with other energy sources or storage systems to enhance the overall efficiency, reliability, and cost-effectiveness of power generation [17]. [Figure 1](#), illustrates renewable energy contribution globally. These systems are

classified based on the combination of PV with other energy sources, and they offer several advantages and disadvantages as the overview of PV integration hybrid systems tabulated in Table 1. The RESs are gain interest among scholars in various applications due to their wide advantages. The commonly provided advantages for perfection purposes are continued cost reduction, increased deployment, energy internet and decentralization, and technological innovations.

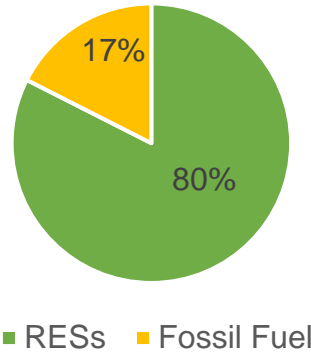

Figure 1. Renewable energy contribution globally.

Table 1. Classification of PV systems [18,19].

PV Systems Classifications	Features
PV-Diesel Hybrid Systems	<ul style="list-style-type: none"> • These systems combine PV with diesel generators. • PV arrays generate electricity during daylight hours, reducing the need for diesel fuel consumption. • Diesel generators are used as backup or supplemental power sources when solar energy is insufficient or during periods of high demand.
PV-Wind Hybrid Systems	<ul style="list-style-type: none"> • These systems combine PV with wind turbines. • Solar PV and wind power complement each other, as PV tends to generate more energy during the day, while wind power production is higher during the night and in certain weather conditions. • The combination of the two sources improves power generation stability and reduces reliance on a single energy source
PV-Battery Hybrid Systems	<ul style="list-style-type: none"> • These systems integrate PV with energy storage systems, typically using batteries. • During periods of PV generation excess, the surplus energy is stored in the batteries for use during times of low or no PV generation. • This enhances self-consumption, load shifting, and system resilience.

3. Types of Renewable Energy Sources

The untapped potential of renewable energy sources, particularly solar and wind energy, in Libya and other North African countries remains a significant concern [27]. Despite the abundant opportunities, barriers and challenges have hindered the widespread adoption of these clean energy solutions [28]. Regulatory flaws, conflicting administrative capabilities, and insufficient financial support within the energy sector are among the critical factors contributing to this situation [29]. The Libyan National Oil Corporation (NOC) has emerged as a potential catalyst for change in this landscape, recently expressing its commitment to play a leading role in advancing renewable energies as part of a comprehensive decarbonization agenda [30]. Although the NOC currently lacks a specific administrative mandate for renewable energy, its financial resources and administrative capacity position it to undertake ambitious megaprojects and develop the necessary infrastructure for exporting green energy to Europe, with green hydrogen expected to play a significant role [32].

A comprehensive analysis of renewable energy technologies reveals a diverse array of solutions with unique applications, as outlined in Table 3. These technologies hold immense importance in reducing dependence on fossil fuels and mitigating climate change effects. Their versatility spans various sectors, encompassing electricity generation, heating, transportation, and even industrial processes. Furthermore, North African countries are starting to explore their geothermal potential, recognizing it

as a clean and reliable energy source. This strategic move aligns with their commitment to diversify energy resources and reduce greenhouse gas emissions.

Despite the progress made in the renewable energy sector, several challenges persist and require careful attention. Securing sufficient funding for renewable energy projects remains a critical obstacle, and addressing technical and logistical complexities is essential to ensure smooth implementation. Moreover, improvements in grid infrastructure are necessary to accommodate the integration of renewable energy sources into the existing power system. Creating regulatory frameworks that foster investment in renewables is equally crucial to attract private sector participation in the development and deployment of clean energy solutions.

Table 3. Renewable energy sources types and their applications [33-36].

Energy sources	Explanation	Applications
Solar Power	Solar panels convert sunlight into electricity, which can be used to power homes, buildings, and even entire cities	<ul style="list-style-type: none"> It is widely used for generating electricity and heating water.
Wind Power	Wind turbines harness the kinetic energy of the wind and convert it into electricity.	<ul style="list-style-type: none"> They are used primarily to generate electricity on a large scale in wind farms.
Hydropower	Hydropower uses the energy of flowing or falling water to generate electricity.	<ul style="list-style-type: none"> It is commonly used in hydroelectric power plants, where dams built to store water and release it in a controlled manner to drive turbines.
Biomass Energy	Biomass refers to organic matter like wood, crop residues, or even dedicated energy crops that can be converted into energy.	<ul style="list-style-type: none"> Biomass can be burned to produce heat or converted into biofuels for transportation and electricity generation.
Geothermal Energy	Geothermal power utilizes the heat from the earth's core.	<ul style="list-style-type: none"> It involves tapping into underground reservoirs of steam hot water and converting it into electricity or directly using it for heating.
Tidal Energy	Tidal power harnesses the energy from the rise and fall of tides to generate electricity	<ul style="list-style-type: none"> Special turbines are placed underwater to capture the kinetic energy of the moving tides

In summary, this study sheds light on the various types of renewable energy sources and their potential in Libya and North African countries. It underscores the importance of addressing barriers and harnessing the leadership potential of the NOC to drive the renewable energy transition. The significance of renewable energy technologies in diverse applications is highlighted, while the exploration of geothermal energy represents a promising avenue. However, concerted efforts are required to overcome challenges, such as securing funding, tackling technical obstacles, enhancing infrastructure, and establishing supportive regulatory environments to accelerate the adoption of renewable energy and pave the way toward a sustainable energy future in the region.

4. Structure of PV System

A photovoltaic power generation station, commonly known as a solar power plant or solar farm, is a facility that converts sunlight into electricity using photovoltaic (PV) panels. These stations are designed to generate large-scale solar energy and contribute to renewable energy production. Below listed several key features and components of a PV power generation station. Further explanation is provided in [Figure 2](#) for the PV structure system.

- Solar Panels:** The primary component of the power station is the solar panels or PV modules. These panels are made up of multiple photovoltaic cells that convert sunlight directly into electricity using the photovoltaic effect.

- **Mounting Structures:** The solar panels are mounted on metal structures or racks to optimize their exposure to sunlight. The mounting structures are designed to withstand various weather conditions and ensure the optimal tilt and orientation of the panels for maximum energy production.
- **Inverters:** The DC (direct current) electricity generated by the solar panels is converted into AC (alternating current) electricity using inverters. Inverters are installed at the solar farm to convert the electricity to a form that can be easily transmitted and distributed through the power grid.
- **Transformers:** Transformers are used to step up or step down the voltage of the electricity generated by the solar farm. Higher voltage levels are more efficient for long-distance transmission, while lower voltage levels are suitable for local distribution.
- **Monitoring and Control Systems:** A photovoltaic power generation station is equipped with monitoring and control systems to manage and optimize the performance of the solar farm. These systems provide real-time data on energy production, panel efficiency, and overall system performance.
- **Grid Connection:** Solar power plants are connected to the electrical grid to distribute the electricity they generate. They may operate in parallel with other power generation sources or supply electricity directly to the grid.
- **Substation:** A substation is typically installed at the solar farm to manage the flow of electricity between the solar power plant and the grid. It includes various protective devices, such as circuit breakers and relays, to ensure safe and reliable operation.
- **Transmission Lines:** Transmission lines are used to transmit the electricity generated by the solar power plant over long distances to reach the areas where it will be consumed. These lines may connect to existing electrical infrastructure or require the construction of new transmission infrastructure.

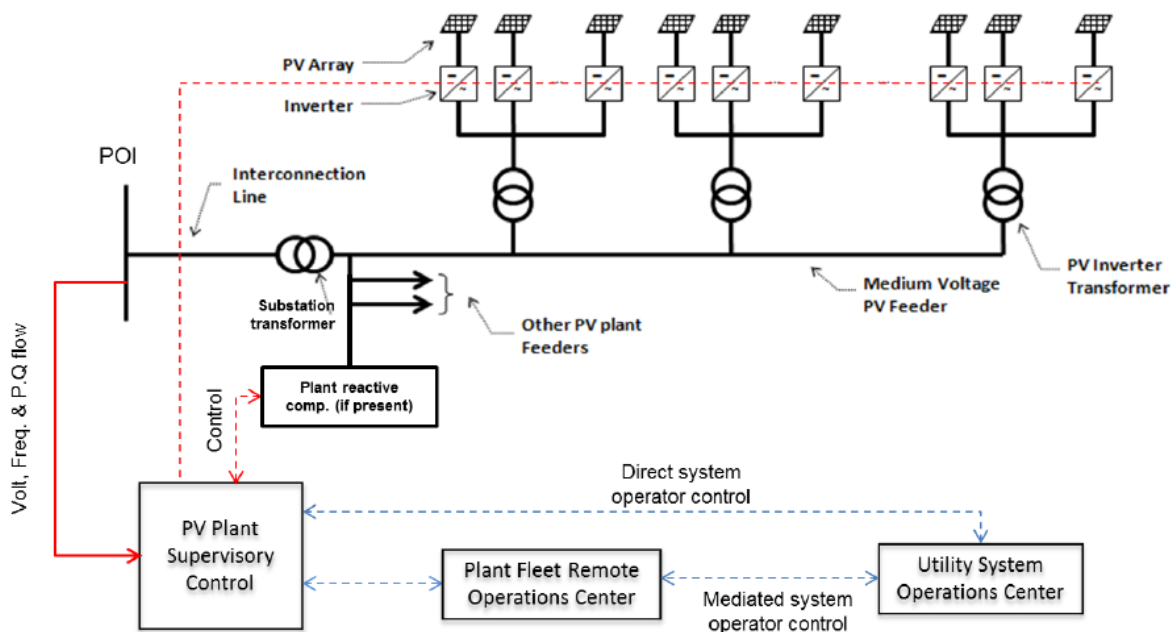

Figure 2. PV structure system.

In this direction, PV power generation stations have emerged as a critical component of the global effort to address environmental challenges and move towards a sustainable energy future. These solar energy facilities are hailed for their environmentally friendly nature, as they harness sunlight to

generate electricity without emitting greenhouse gases, particulate matter, or other harmful pollutants. By relying on abundant solar radiation, PV systems present a promising solution to reduce reliance on fossil fuels and mitigate the adverse effects of traditional energy sources on the environment. One of the key advantages of PV power generation is its potential to contribute significantly to the expansion of RESs. As countries and regions seek to diversify their energy mix and decrease their carbon footprint, PV systems offer a clean and renewable alternative. The sustainable nature of PV power generation aligns with global efforts to combat climate change and reduce the overall environmental impact of energy production and consumption. Moreover, the proliferation of PV power generation stations can lead to energy decentralization, empowering communities and individual consumers to produce their own electricity locally. This decentralization promotes energy independence, resilience, and even the possibility of contributing excess electricity back to the grid, thereby enhancing overall energy security. PV technology continues to advance rapidly, leading to increased efficiency, reduced costs, and enhanced reliability.

5. Solar PV Panel Recycling Plant

A solar photovoltaic (PV) panel recycling plant is a facility specifically designed to process and recycle end-of-life or defective solar panels as tabulated in Table 4 [37]. As the use of solar energy continues to grow, the need for recycling facilities becomes increasingly important to ensure proper disposal of decommissioned panels and the recovery of valuable materials [38]. By establishing and operating a solar PV panel recycling plant, the industry can contribute to reducing the environmental impact of solar panel waste while recovering valuable materials for reuse. It promotes the circular economy and sustainable practices within the solar energy sector.

Table 4. key components and processes for solar PV recycling [37], [39-43].

Key components	Remarks
Collection and Sorting	<ul style="list-style-type: none"> The plant receives used or damaged solar panels from various sources, including residential, commercial, and utility-scale installations. The panels are sorted based on their types, such as crystalline silicon, thin film, or other variations.
Preprocessing	<ul style="list-style-type: none"> The sorted panels undergo preprocessing to remove any external components, such as frames, junction boxes, and cables. This step aims to isolate the panel's main components for further recycling.
Shredding	<ul style="list-style-type: none"> The panels are then shredded into smaller fragments using specialized equipment. Shredding breaks down the panels into smaller pieces, increasing the efficiency of subsequent processes.
Separation and Sorting	<ul style="list-style-type: none"> The shredded material is passed through separation technologies to separate different components, such as glass, semiconductor materials (such as silicon wafers), metals (aluminium frames, copper), and plastics. Various techniques like gravity separation, magnetic separation, and optical sorting are used to achieve efficient separation.
Material Recovery	<ul style="list-style-type: none"> Once separated, the different components are further processed for material recovery. For example, glass can be cleaned, crushed, and recycled into new glass products. The silicon wafers can be reclaimed and used in the production of new solar cells or other semiconductor applications. Metals like aluminium and copper can be melted and reused.
Hazardous Waste Treatment	<ul style="list-style-type: none"> Some solar panels contain hazardous substances like lead, cadmium, or other toxic materials in their composition. The recycling plant must handle and treat these hazardous materials properly, following environmental regulations and safety protocols. Hazardous waste treatment facilities are typically included in the recycling plant to ensure safe disposal of these materials.
Recycling Efficiency and Optimization	<ul style="list-style-type: none"> Continuous research and development efforts are focused on improving recycling techniques and increasing the efficiency of material recovery. Innovations in sorting technologies, chemical treatments, and material extraction methods aim to enhance recycling rates and minimize waste.

Environmental Compliance	<ul style="list-style-type: none"> • Solar panel recycling plants must adhere to local, regional, and national regulations regarding waste management, environmental protection, and worker safety. • Compliance with these regulations ensures that the recycling process is environmentally responsible and safe for workers.
Quality Control	<ul style="list-style-type: none"> • To maintain the quality of recovered materials, quality control procedures are implemented throughout the recycling process. • This ensures that the recycled materials meet the required specifications and can be used as inputs for the production of new solar panels or other products

6. PV Smart Software

According to the Ministry of Renewable Energy Sources (MNRE) and The Energy and Resources Institute (TERI), a variety of Photovoltaic (PV) simulation programs are widely utilized globally for the design of solar PV systems. Seven of the most commonly used sizing tools and simulation software, including Open Architecture Research Tool, have been compiled in Table 5 for reference. These tools have garnered significant attention among researchers for various applications, primarily due to their numerous merits. Notably, they offer technical precision in project sizing, facilitating educational purposes, providing financial insights, enabling in-depth analysis of energy production, and facilitating long-term system estimation [44,45].

Table 5. Smart PV software [46].

Category	Classification	Ref
Sizing tools	HOMER	[45]
	RETScreen	[47]
	PVSYST	[48]
	Proprietary tool	[49]
	Hybrid Designer	[45]
Simulation tools	Ashling	[47]
	Hybrid2	[50]
	INSEL	[47]
	SAM-System Advisor Model	[51]
	PV-DesignPro	[52]
	PVSYST	[53]
	RAPSIM	[54]
	SAU/ARES	[47]
	PV-Online	[55]
	SOMES	[45]
	PVGIS	[56]
	PV*SOL	[57]
	PVWatt	[48]
SOLSIM	[58]	
Open architecture research tool	WATSUN-PV	[59]
	Matlab/Simulink	[60]
	PSpice	[61]
	TRNSYS	[62]

Table 6 presents a comparative analysis of some common simulation tools in terms of cost, availability, location applicability, and provided techniques. This comparison serves as a valuable resource for researchers and practitioners seeking the most suitable simulation tool for their specific requirements and constraints. By assessing these simulation tools based on their respective features and attributes, professionals can make informed decisions regarding their adoption and utilization in the design and assessment of solar PV systems. Furthermore, the availability of such simulation tools plays a crucial role in advancing research and development in the field of solar energy, contributing to the broader goal of achieving sustainable and efficient renewable energy solutions.

Table 6. Comparison of common simulation tools [48].

Description	PV Watt	PVGIS	PV-Online	PV*SOL Online	PVSYS	SAM
Online Simulation Tool	Y	Y	y	Y	N	N
Internet requirement	Y	Y	y	Y	y	Y
Geographical location Map for the selected site	Y	Y	y	Y	N	N
Can it be for all over the world or certain location	Anywhere	Europe, Africa, Asia	Selected cities in particular country	Anywhere	Selected location	Selected location
Free/purchased software	Free	Free	Free	Free	Paid	Free
Technical sizing	Y	Y	Y	Y	Y	Y
Financial Modeling	N	N	N	N	Y	Y
GHG emission Analysis	N	N	N	N	Y	Y

7. Conclusion

In conclusion, the prospects of renewable energy sources (RESs) in North African countries are highly promising, presenting an abundant potential for the development and deployment of various renewable technologies. However, the realization of this potential necessitates sustained support, substantial investment, and collaborative efforts to fully harness the benefits of RESs and pave the way towards a sustainable energy future in the region. Remarkable attributes, including abundant solar radiation, robust wind resources, and promising geothermal reservoirs, render the North African region highly favorable for implementing renewable energy projects. Recognizing the significance of transitioning to cleaner energy options, North African countries have embarked on initiatives to diversify their energy portfolio, curtail carbon emissions, and enhance energy security. Notably, countries such as Morocco, Tunisia, and Egypt have demonstrated commitment by taking significant strides to foster renewable energy investments, accompanied by ambitious targets to elevate the contribution of renewables in their energy mix. The utilization of advanced smart software has proven pivotal for engineers and consumers alike, facilitating precise power estimation and analysis to optimize the utilization of renewable energy systems. Embracing the vast potential and fostering advancements in renewable energy technologies will drive the region towards a sustainable and resilient energy landscape, bolstering economic growth, environmental stewardship, and energy self-reliance.

Author Contributions: All authors listed have made a substantial, direct, and intellectual contribution to the work and approved it for publication.

Funding: This research received no external funding.

Data Availability Statement: Not applicable.

Acknowledgements: We would like to express our sincere gratitude and appreciation to the Department of Electrical & Electronics Engineering, Faculty of Technical Sciences – Sebha, Libya for their invaluable support and assistance in the successful completion of our article.

Conflicts of Interest: The authors declare no conflict of interest.

References

- [1] J. Krupa, R. Poudineh, and L. D. D. Harvey, "Renewable electricity finance in the resource-rich countries of the Middle East and North Africa: A case study on the Gulf Cooperation Council," *Energy*, vol. 166, pp. 1047–1062, Jan. 2019, doi: 10.1016/j.energy.2018.10.106.

- [2] A. Banerji, K. Sharma, and R. R. Singh, "Integrating Renewable Energy and Electric Vehicle Systems into Power Grid: Benefits and Challenges," in *2021 Innovations in Power and Advanced Computing Technologies (i-PACT)*, IEEE, Nov. 2021, pp. 1–6. doi: 10.1109/i-PACT52855.2021.9696887.
- [3] M. A. Lange, "Impacts of climate change on the Eastern Mediterranean and the Middle East and North Africa region and the water-energy nexus," *Atmosphere (Basel)*, vol. 10, no. 8, 2019, doi: 10.3390/atmos10080455.
- [4] M. R. H. Mojumder, F. Ahmed Antara, M. Hasanuzzaman, B. Alamri, and M. Alsharif, "Electric Vehicle-to-Grid (V2G) Technologies: Impact on the Power Grid and Battery," *Sustainability*, vol. 14, no. 21, p. 13856, Oct. 2022, doi: 10.3390/su142113856.
- [5] I. Ullah, Z. Khitab, M. Khan, and S. Hussain, "An Efficient Energy Management in Office Using Bio-Inspired Energy Optimization Algorithms," *Processes*, vol. 7, no. 3, p. 142, Mar. 2019, doi: 10.3390/pr7030142.
- [6] A. Alsharif, C. Wei, R. Ayop, K. Yiew, and A. Moh, "A rule-based power management strategy for Vehicle-to-Grid system using antlion sizing optimization," *J. Energy Storage*, vol. 41, no. April, p. 102913, 2021, doi: 10.1016/j.est.2021.102913.
- [7] A. O. M. Maka and J. M. Alabid, "Solar energy technology and its roles in sustainable development," *Clean Energy*, vol. 6, no. 3, pp. 476–483, Jun. 2022, doi: 10.1093/ce/zkac023.
- [8] M. Khaleel, Z. Yusupov, Y. Nassar, H. J. El-khozondar, A. Ahmed, and A. Alsharif, "Technical challenges and optimization of superconducting magnetic energy storage in electrical power systems," *e-Prime-Advances in Electrical Engineering, Electronics and Energy*, vol. 5, no. 100223, pp. 1–14, 2023.
- [9] M. M. Khaleel, A. Alsharif, and I. I. K. Imbayah, "Renewable energy technologies: Recent advances and future predictions," *African Journal of Advanced Pure and Applied Sciences (AJAPAS)*, vol. 1, no. 3, pp. 58–64, 2022.
- [10] Y. F. Nassar et al., "Regression model for optimum solar collectors' tilt angles in Libya," in *2023 8th International Engineering Conference on Renewable Energy & Sustainability (ieCRES)*, 2023, pp. 1–6.
- [11] F. El Ghazi, M. B. Sedra, and M. Akdi, "Energy transition from fossil to renewable sources in North Africa: Focus on the renewable electricity generation in Morocco," *Int. J. Energy Econ. Policy*, vol. 11, no. 3, pp. 236–242, 2021, doi: 10.32479/ijeeep.11036.
- [12] A. O. M. Maka, S. Salem, and M. Mehmood, "Solar photovoltaic (PV) applications in Libya: Challenges, potential, opportunities and future perspectives," *Clean. Eng. Technol.*, vol. 5, p. 100267, 2021, doi: 10.1016/j.clet.2021.100267.
- [13] H. A. Behabtu et al., "A Review of Energy Storage Technologies' Application Potentials in Renewable Energy Sources Grid Integration," *Sustainability*, vol. 12, no. 24, p. 10511, Dec. 2020, doi: 10.3390/su122410511.
- [14] S. Koochi-Fayegh and M. A. Rosen, "A review of energy storage types, applications and recent developments," *J. Energy Storage*, vol. 27, no. July 2019, p. 101047, 2020, doi: 10.1016/j.est.2019.101047.
- [15] Y. Nassar et al., "Solar and wind atlas for Libya," *International Journal of Electrical Engineering and Sustainability (IJEES)*, vol. 1, no. 3, pp. 27–43, 2023.
- [16] I. Alhammi and A. A. Alhengari, "Enhancing Time Consuming Computation of Probabilistic Available Transfer Capability with Wind Resources using Probabilistic Collocation Method," in *2022 IEEE 2nd International Maghreb Meeting of the Conference on Sciences and Techniques of Automatic Control and Computer Engineering, MI-STA 2022 - Proceeding*, 2022, pp. 716–721. doi: 10.1109/MI-STA54861.2022.9837701.
- [17] M. Almaktar, A. M. Elbreki, and M. Shaaban, "Revitalizing operational reliability of the electrical energy system in Libya: Feasibility analysis of solar generation in local communities," *J. Clean. Prod.*, vol. 279, p. 123647, 2021, doi: 10.1016/j.jclepro.2020.123647.
- [18] Y. F. Nassar et al., "Thermoelectrical analysis of a new hybrid PV-thermal flat plate solar collector," in *2023 8th International Engineering Conference on Renewable Energy & Sustainability (ieCRES)*, 2023, pp. 1–5.
- [19] M. M. Khaleel, Z. Yusupov, M. T. Güneşer, A. A. Abulifa, A. A. Ahmed, and A. Alsharif, "The effect of PEMFC on power grid using advanced equilibrium optimizer and particle swarm optimisation for voltage sag mitigation," in *2023 IEEE 3rd International Maghreb Meeting of the Conference on Sciences and Techniques of Automatic Control and Computer Engineering (MI-STA)*, 2023, pp. 755–760.
- [20] A. Roy, F. Auger, J. Olivier, E. Schaeffer, and B. Auvity, "Design, Sizing, and Energy Management of Microgrids in Harbor Areas: A Review," *Energies*, vol. 13, no. 20, p. 5314, Oct. 2020, doi: 10.3390/en13205314.
- [21] S. Abdulwahab, Y. F. Nassar, H. J. El-Khozondar, M. Khaleel, A. A. Ahmed, and A. Alsharif, "Meeting solar energy demands: Significance of transposition models for solar irradiance," *International Journal of Electrical Engineering and Sustainability (IJEES)*, pp. 90–105, 2023.
- [22] A. Alsharif, C. W. Tan, R. Ayop, K. Y. Lau, and A. M. Dobi, "A rule-based power management strategy for

- Vehicle-to-Grid system using antlion sizing optimization," *J. Energy Storage*, vol. 41, no. July, p. 102913, Sep. 2021, doi: 10.1016/j.est.2021.102913.
- [23] S. Habib, M. M. Khan, F. Abbas, L. Sang, M. U. Shahid, and H. Tang, "A Comprehensive Study of Implemented International Standards, Technical Challenges, Impacts and Prospects for Electric Vehicles," *IEEE Access*, vol. 6, no. c, pp. 13866–13890, Mar. 2018, doi: 10.1109/ACCESS.2018.2812303.
- [24] S. Habib, M. M. Khan, J. Huawei, K. Hashmi, M. T. Faiz, and H. Tang, "A study of implemented international standards and infrastructural system for electric vehicles," in *2018 IEEE International Conference on Industrial Technology (ICIT)*, IEEE, Feb. 2018, pp. 1783–1788. doi: 10.1109/ICIT.2018.8352454.
- [25] T. Mo, Y. Li, K. Lau, C. K. Poon, Y. Wu, and Y. Luo, "Trends and Emerging Technologies for the Development of Electric Vehicles," *Energies*, vol. 15, no. 17, p. 6271, Aug. 2022, doi: 10.3390/en15176271.
- [26] T. Ahmad and D. Zhang, "Renewable energy integration/techno-economic feasibility analysis, cost/benefit impact on islanded and grid-connected operations: A case study," *Renew. Energy*, vol. 180, no. August, pp. 83–108, Dec. 2021, doi: 10.1016/j.renene.2021.08.041.
- [27] M. Khaleel, Z. Yusupov, A. A. Ahmed, A. Alsharif, A. Alarga, and I. Imbayah, "The effect of digital technologies on energy efficiency policy," *International Journal of Electrical Engineering and Sustainability (IJEES)*, pp. 1–8, 2023.
- [28] A. Alsharif, A. Salem, D. Alarga, and A. A. Ahmed, "Stochastic Method and Sensitivity Analysis Assessments for Vehicle-to-Home Integration based on Renewable Energy Sources".
- [29] H. Moria and M. Elmnifi, "Feasibility Study into Possibility Potentials and Challenges of Renewable Energy in Libya," *Int. J. Adv. Sci. Technol.*, vol. 29, no. 3, pp. 46–60, 2020.
- [30] H. Wang, A. Balasubramani, and Z. Ye, "Optimal Planning of Renewable Generations for Electric Vehicle Charging Station," in *2018 International Conference on Computing, Networking and Communications (ICNC)*, IEEE, Mar. 2018, pp. 63–67. doi: 10.1109/ICCNC.2018.8390352.
- [31] B. Akbas, A. S. Kocaman, D. Nock, and P. A. Trotter, "Rural electrification: An overview of optimization methods," *Renew. Sustain. Energy Rev.*, vol. 156, p. 111935, Mar. 2022, doi: 10.1016/j.rser.2021.111935.
- [32] M. Almaktar and M. Shaaban, "Prospects of renewable energy as a non-rivalry energy alternative in Libya," *Renew. Sustain. Energy Rev.*, vol. 143, no. September 2020, p. 110852, 2021, doi: 10.1016/j.rser.2021.110852.
- [33] L. Olatomiwa, S. Mekhilef, M. S. Ismail, and M. Moghavvemi, "Energy management strategies in hybrid renewable energy systems: A review," *Renew. Sustain. Energy Rev.*, vol. 62, pp. 821–835, 2016, doi: 10.1016/j.rser.2016.05.040.
- [34] T. F. Agajie *et al.*, "A Comprehensive Review on Techno-Economic Analysis and Optimal Sizing of Hybrid Renewable Energy Sources with Energy Storage Systems," *Energies*, vol. 16, no. 2, p. 642, Jan. 2023, doi: 10.3390/en16020642.
- [35] A. M. Makhzom *et al.*, "Carbon dioxide Life Cycle Assessment of the energy industry sector in Libya: A case study," *International Journal of Electrical Engineering and Sustainability (IJEES)*, pp. 145–163, 2023.
- [36] A. Razmjoo, L. Gakenia Kaigutha, M. A. Vaziri Rad, M. Marzband, A. Davarpanah, and M. Denai, "hcnical analysis investigating energy sustainability utilizing reliable renewable energy sources to reduce CO2 emissions in a high potential area," *Renew. Energy*, vol. 164, pp. 46–57, Feb. 2021, doi: 10.1016/j.renene.2020.09.042.
- [37] S. Barakat, H. Ibrahim, and A. A. Elbaset, "Multi-objective optimization of grid-connected PV-wind hybrid system considering reliability, cost, and environmental aspects," *Sustain. Cities Soc.*, vol. 60, p. 102178, Sep. 2020, doi: 10.1016/j.scs.2020.102178.
- [38] A. Alsharif, C. W. Tan, R. Ayop, A. Dobi, and K. Y. Lau, "A comprehensive review of energy management strategy in Vehicle-to-Grid technology integrated with renewable energy sources," *Sustain. Energy Technol. Assessments*, vol. 47, no. xxxx, p. 101439, Oct. 2021, doi: 10.1016/j.seta.2021.101439.
- [39] N. M. Kumar, P. R. K. Reddy, and K. Praveen, "Optimal energy performance and comparison of open rack and roof mount mono c-Si photovoltaic Systems," *Energy Procedia*, vol. 117, pp. 136–144, Jun. 2017, doi: 10.1016/j.egypro.2017.05.116.
- [40] M. Khaleel, Z. Yusupov, N. Yasser, and H. J. El-Khozondar, "Enhancing Microgrid performance through hybrid energy storage system integration: ANFIS and GA approaches," *International Journal of Electrical Engineering and Sustainability (IJEES)*, pp. 38–48, 2023.
- [41] S. Barakat, H. Ibrahim, and A. A. Elbaset, "Multi-objective optimization of grid-connected PV-wind hybrid system considering reliability, cost, and environmental aspects," *Sustain. Cities Soc.*, vol. 60, no. March, p. 102178, 2020, doi: 10.1016/j.scs.2020.102178.
- [42] E. I. Come Zebra, H. J. van der Windt, G. Nhumaio, and A. P. C. Faaij, "A review of hybrid renewable energy systems in mini-grids for off-grid electrification in developing countries," *Renew. Sustain. Energy Rev.*, vol. 144, no. April, p. 111036, Jul. 2021.
- [43] Melody Bomgardner and Alex Scott, "Recycling renewables," *C&EN Glob. Enterp.*, vol. 96, no. 15, pp. 34–

- 41, 2018, doi: 10.1021/cen-09615-cover1.
- [44] S. Sinha and S. S. Chandel, "Review of software tools for hybrid renewable energy systems," *Renew. Sustain. Energy Rev.*, vol. 32, pp. 192–205, 2014, doi: 10.1016/j.rser.2014.01.035.
- [45] N. Manoj Kumar, "Simulation Tools for Technical Sizing and Analysis of Solar PV Systems," in *6th World Conference on Applied Sciences, Engineering & Technology, UMPO, Indonesia*, 2017, p. 6.
- [46] W. Ma, X. Xue, and G. Liu, "Techno-economic evaluation for hybrid renewable energy system: Application and merits," *Energy*, vol. 159, pp. 385–409, 2018, doi: 10.1016/j.energy.2018.06.101.
- [47] D. Turcotte, M. Rossb, and F. Sheriffa, "Photovoltaic Hybrid System Sizing And Simulation Tools: Status And Needs," *PV Horiz. Work. Photovolt. Hybrid Syst.*, vol. 13, no. 10 septembre, pp. 1–10, 2001.
- [48] N. Manoj Kumar, "Simulation Tools for Technical Sizing and Analysis of Solar PV Systems," *6th World Conf. Appl. Sci. Eng. Technol.*, no. August, pp. 26–27, 2017.
- [49] T. Lemlouma, S. Laborie, and P. Roose, "Toward a context-aware and automatic evaluation of elderly dependency in smart homes and cities," *2013 IEEE 14th Int. Symp. a World Wireless, Mob. Multimed. Networks, WoWMoM 2013*, pp. 1–6, 2013, doi: 10.1109/WoWMoM.2013.6583501.
- [50] M. A. M. Ramli, H. R. E. H. Boucekara, and A. S. Alghamdi, "Optimal sizing of PV/wind/diesel hybrid microgrid system using multi-objective self-adaptive differential evolution algorithm," *Renew. Energy*, vol. 121, pp. 400–411, 2018, doi: 10.1016/j.renene.2018.01.058.
- [51] "SAM-System Advisor Model." [Online]. Available: <https://sam.nrel.gov/download>
- [52] "PV-DesignPro." [Online]. Available: <https://sourceforge.net/software/product/PV-DesignPro/>
- [53] N. M. Kumar, M. R. Kumar, P. R. Rejoice, and M. Mathew, "Performance analysis of 100 kWp grid connected Si-poly photovoltaic system using PVsyst simulation tool," *Energy Procedia*, vol. 117, pp. 180–189, 2017, doi: 10.1016/j.egypro.2017.05.121.
- [54] D. Mazzeo, N. Matera, P. De Luca, C. Baglivo, P. M. Congedo, and G. Oliveti, "A literature review and statistical analysis of photovoltaic-wind hybrid renewable system research by considering the most relevant 550 articles: an upgradable matrix literature database," *J. Clean. Prod.*, p. 126070, Jan. 2021, doi: 10.1016/j.jclepro.2021.126070.
- [55] "PV Online." [Online]. Available: <https://pvsol-online.valentin-software.com/#/>
- [56] "PVGIS." [Online]. Available: https://joint-research-centre.ec.europa.eu/photovoltaic-geographical-information-system-pvgis_en
- [57] "PV*SOL." [Online]. Available: <https://pvsol.software/en/>
- [58] C. Schaffrin and I. Knoblich, "SolSim – A Software Tool for Simulation of Solar Hybrid Systems," in *Sixteenth European Photovoltaic Solar Energy Conference*, Routledge, 2020, pp. 2440–2444. doi: 10.4324/9781315074405-98.
- [59] B. M. Jatzeck and A. M. Robinson, "WATSUN-PV 4.0 modifications to include wind turbine generator, AC load shedding, and operation with zero-capacity diesel generator," in *Proceedings of 1996 Canadian Conference on Electrical and Computer Engineering*, IEEE, pp. 655–658. doi: 10.1109/CCECE.1996.548238.
- [60] A. Beck, *Introduction to Nonlinear Optimization: Theory, Algorithms, and Applications with MATLAB*. 2014. [Online]. Available: <https://books.google.com/books?id=VvYeBQAAQBAJ&pgis=1>
- [61] "PSPICE." [Online]. Available: <https://www.orcad.com/pspice>
- [62] Y. E. García Vera, R. Dufo-López, and J. L. Bernal-Agustín, "Energy Management in Microgrids with Renewable Energy Sources: A Literature Review," *Appl. Sci.*, vol. 9, no. 18, p. 3854, Sep. 2019, doi: 10.3390/app9183854.